

Please read instructions in their entirety before proceeding with any part of the installation. This luminaire must be installed in accordance with the National Electric Code and local regulations. Use of ballasts or other components not supplied by Vode Lighting voids warranty. To prevent electric shock, turn off electricity at the fuse box before proceeding. Do not install this product in wet locations. UL listed for dry and damp locations only. Retain instructions for future reference. Technical Support: 707-996-9898

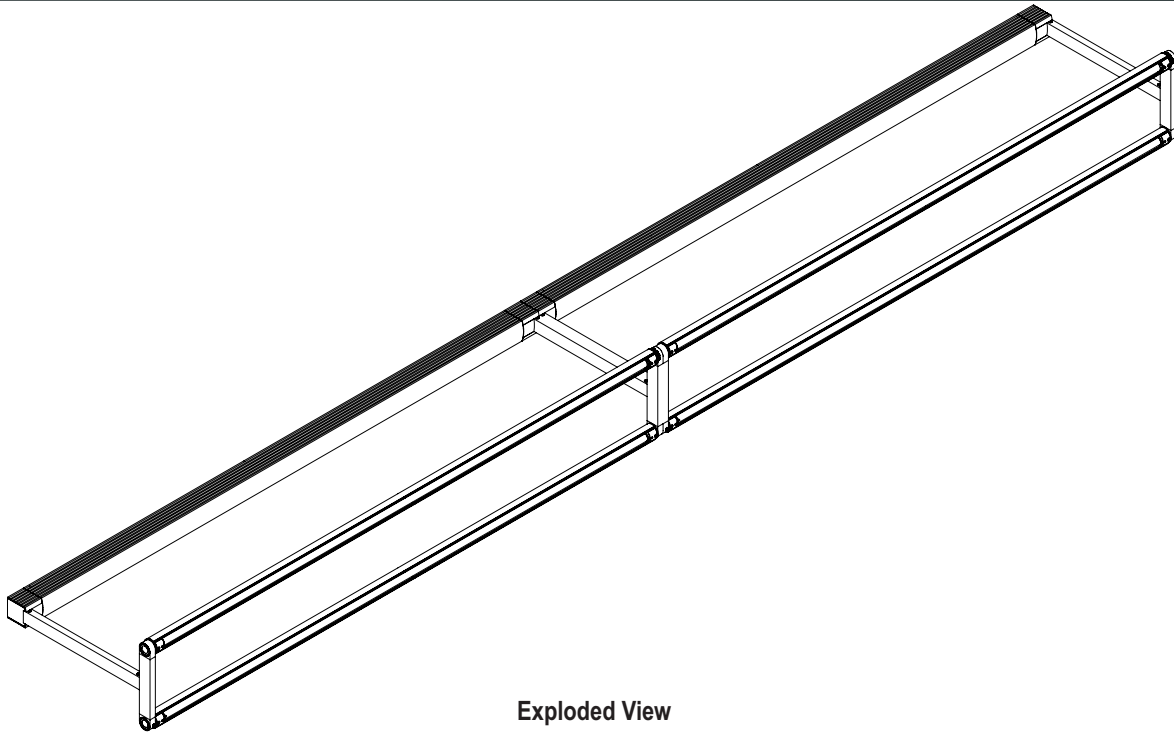

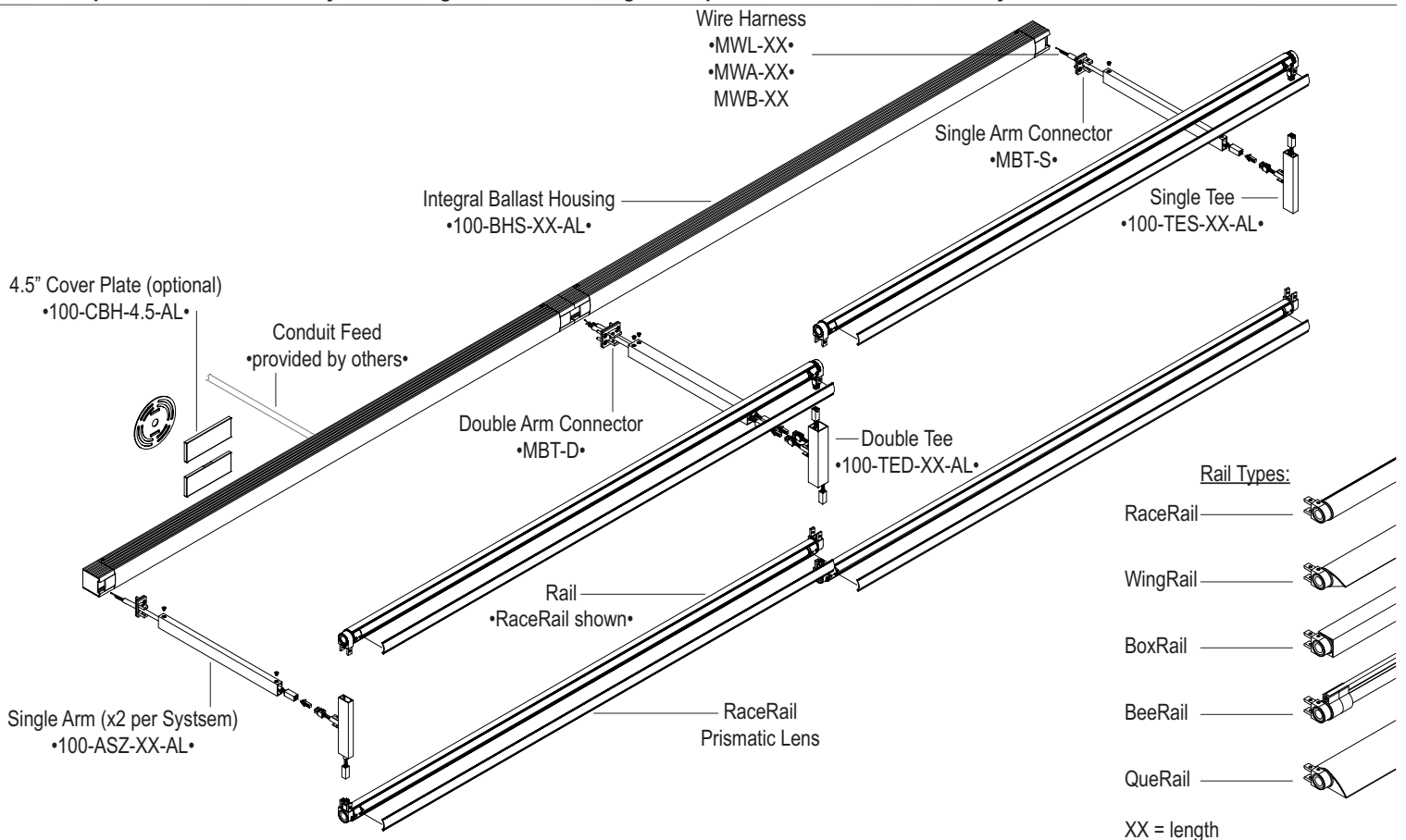



Exploded View

Components for Vode MLR System • Integral Ballast Housing • 1 lamp • Double Rail • Continuous System with 24", 36", 48" or 60" Rails

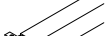

Rail Types:

- RaceRail 
- WingRail 
- BoxRail 
- BeeRail 
- QueRail 

XX = length

**1 Preparing Integral Ballast Housing for Installation:**

Remove Ballast Housing Cover, be careful not to damage the finish.  
 Remove End Covers on ends that will be connected as shown.

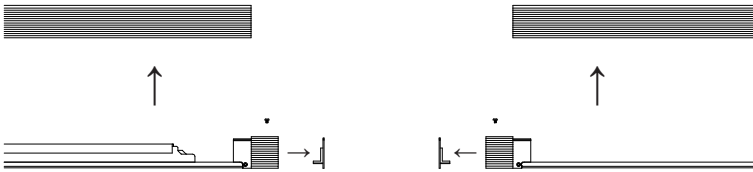

**2 Preparing Arms for Installation:**

Each Single Arm takes one Wire Harness, Double Arms take two Wire Harness.  
 Slip Wire Harness through Arm and Arm Connector as shown.  
 Secure Arm to Arm Connector using screws provided.  
 Make sure to leave 1" of wire hanging out of the Arm.

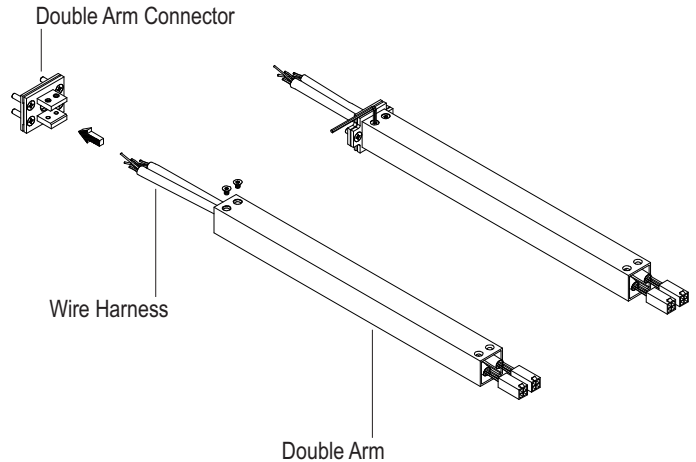

**3 Installing Back Plates to Surface using Cover Plates:**

Direct conduit feed is recommended but Integral Ballast Housing will mount to any standard j-box. For direct conduit feed see step 4.

Feed Wires through Mounting Plate, secure using provided screws.  
 Mounting Plate slots should align with desired mount positions, (vertical or horizontal). Insert wires through knock-out holes, most back-plates are provided with 3 knock-out holes, see page 4 for knock-out locations.

Mounting BHS back-plate to blocking is strongly recommended. Blocking is also recommended at ALL arm junctions.

Install back-plate to surface making sure its leveled and installed exactly between both cover plates. Alignment of first Ballast Housing is critical as it will determine the line of entire System. Secure back-plate to surface using screws provided.

DO NOT power on System at this time.

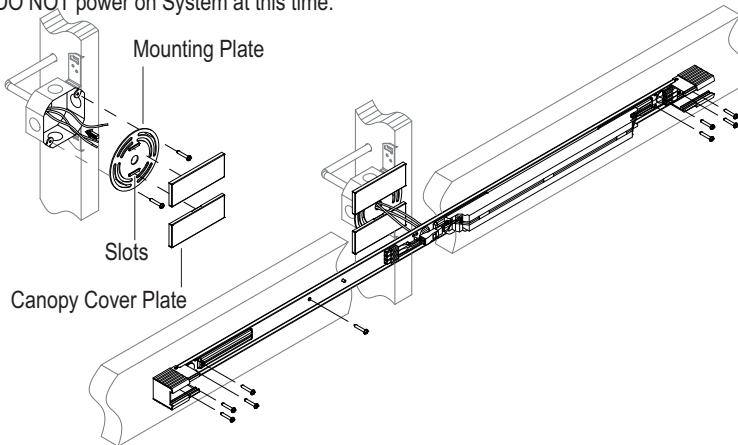

**4 Direct Conduit Feed:**

Attach conduit to BHS back-plate using conduit adaptor (provided by others).

Most BHS back-plates are provided with 3 knock-out holes, see page 4 for knock-out locations.

Mounting BHS back-plate to blocking is strongly recommended.  
 DO NOT power on System at this time.

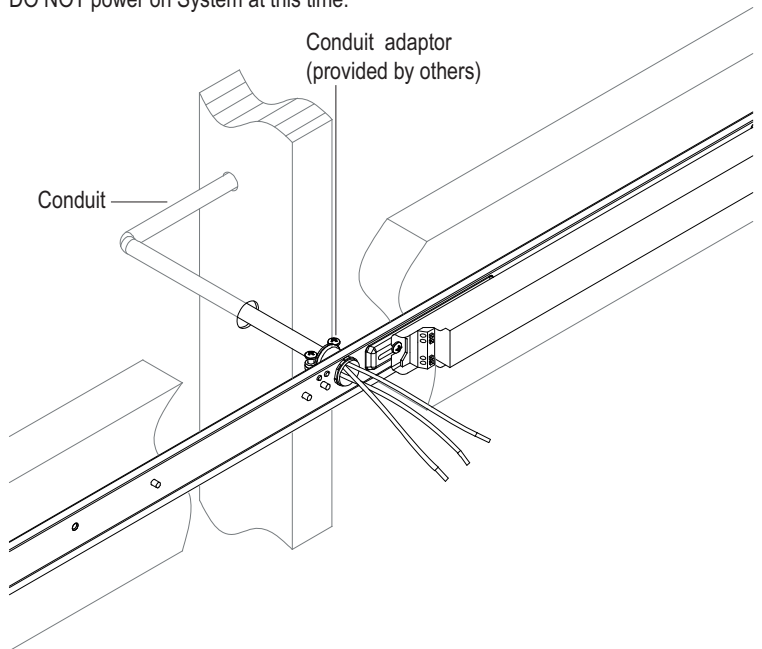

**5 Installing Additional BHS Back-Plates:**

Install Double Arm on ALL mid-sections, run one Wire Harness to each BHS back-plate. Arms must be centered between BHS End-Block as shown.  
 Align additional sections using Double Arms as guide. Make sure to leave 1" of Wire Harness hanging out of Arm. Make line power connections to Connector Disconnect provided by Vode.  
 Each Back-Plate is provided with a Connector Disconnect to bring power in wherever desired.  
 Make Power Harness (provided by Vode) connections on all joint-sections. All Back-Plates are provided with Power Hanress. Make sure mating connectors are completely secured. Make sure additional sections are leveled with first sections before securing additional section to surface, make sure joint BHS end blocks are tight and even. Tighten screws on all arms and repeat steps if additional sections are needed.  
 DO NOT power on System at this time.

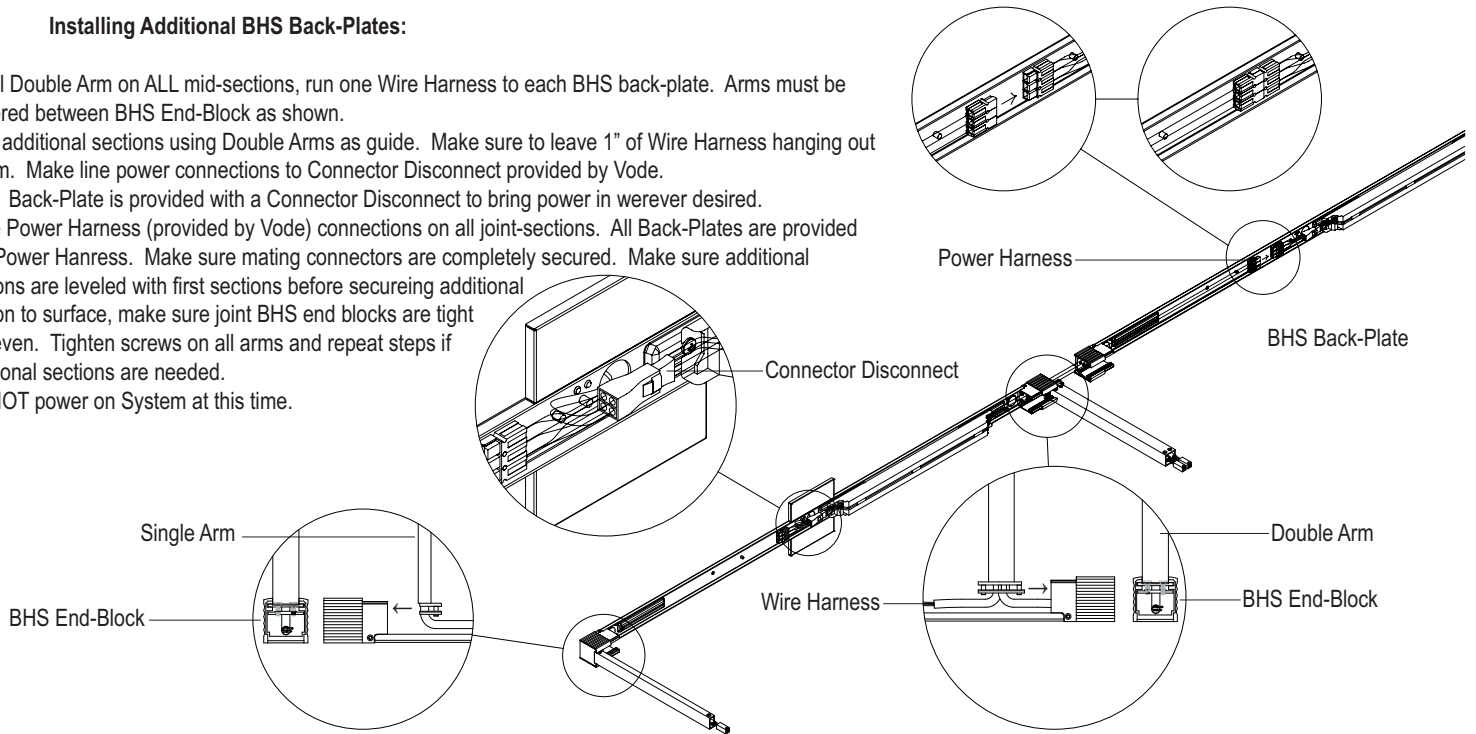

**6 Installing Tees:**

Before installing Tees, check wiring diagram on page 4 for correct Tee orientation.  
 If using WingRail on system, also check "WingRail Orientation Install" layout sheet provided by Vode.

Make Wire Harness connections between Arm and Tee as shown.  
 Make sure mating connector parts are completely secured.  
 Secure Tee to Arm using provided screws.

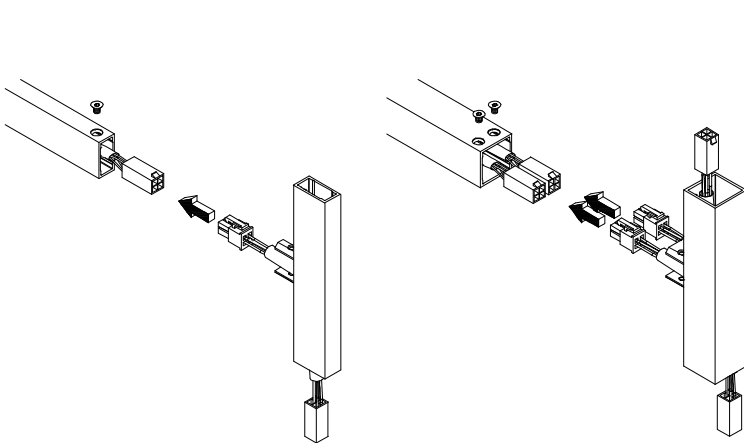

**7 Installing Rails:**

Snap connector on Tee to mating connector on Rail.  
 Make sure mating connector parts are completely secured.  
 Secure Rail to Tee using provided screws.

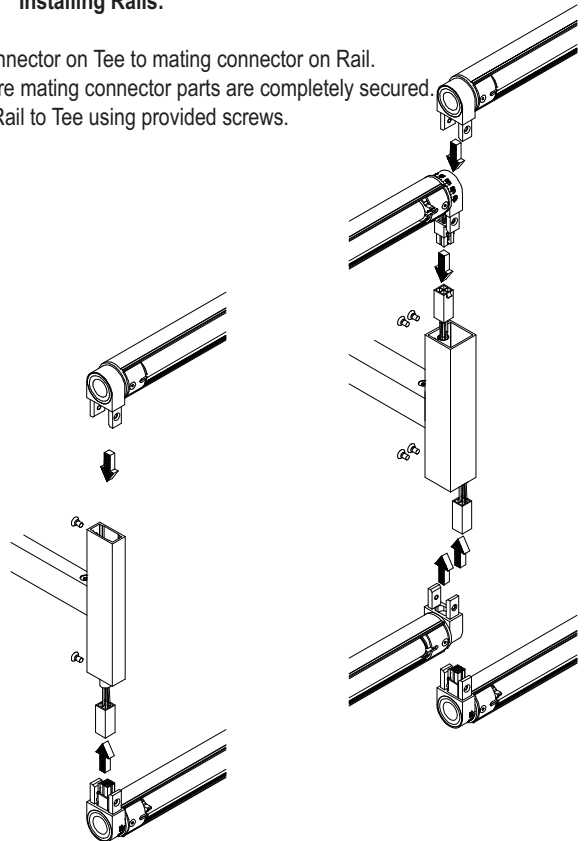

**8 Installing Lamps & Adjusting Rails:**

**IMPORTANT:** Use only T5 lamps in correct wattage! See label inside Rail.

Install lamps. For WingRail, BoxRail and RaceRail (shown), turn socket rotor tab to properly position and secure lamp. If lens is applied, install lens. Power-on system and let lamps burn in per lamp manufacturers recommendations (usually 50-100 hours).

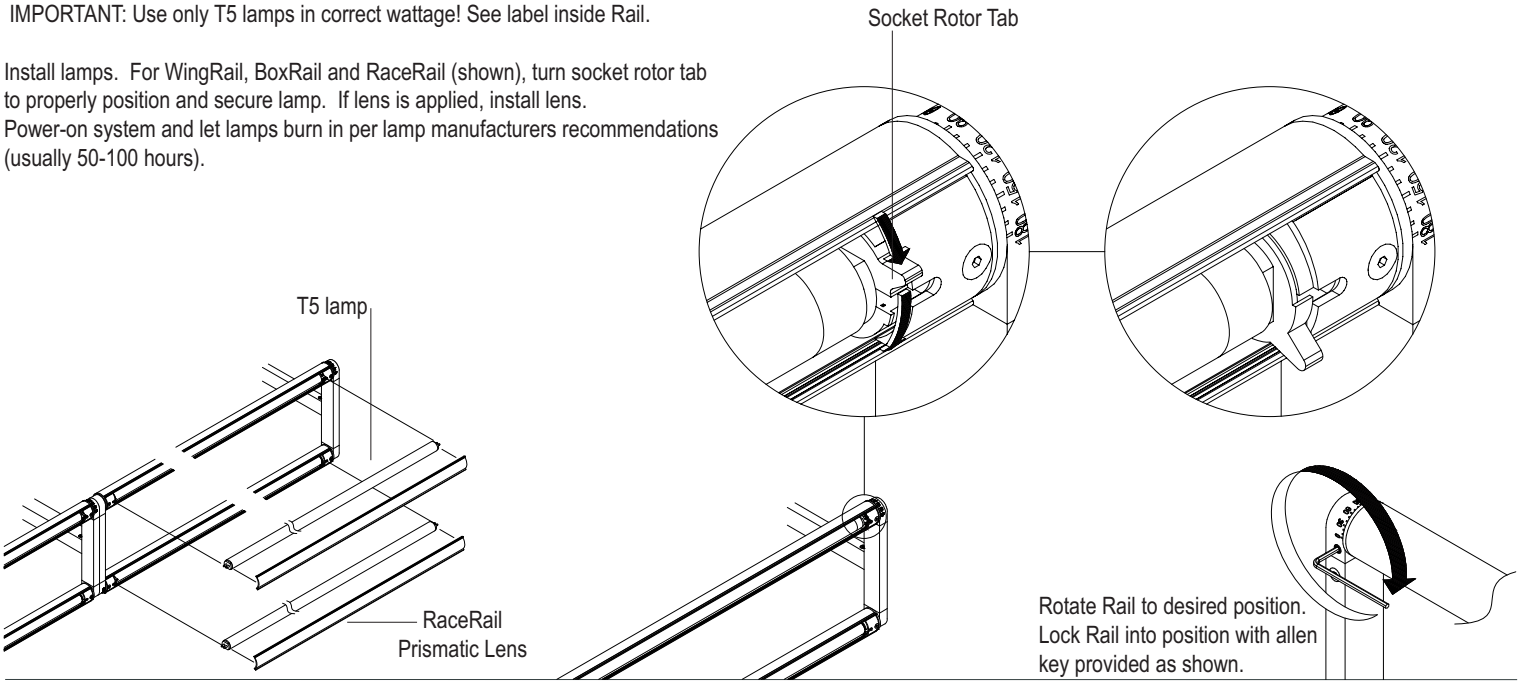

**9 Replace Ballast Housing Cover:**

After checking the entire System and making sure all connections are properly working, install Slip Plates as shown below. Replace Ballast Housing Covers making sure wires are not pinched when snapping cover on BHS back-plate. It is recommended that Cover mounting screws are located on top side when Wall Mount Systems are installed.

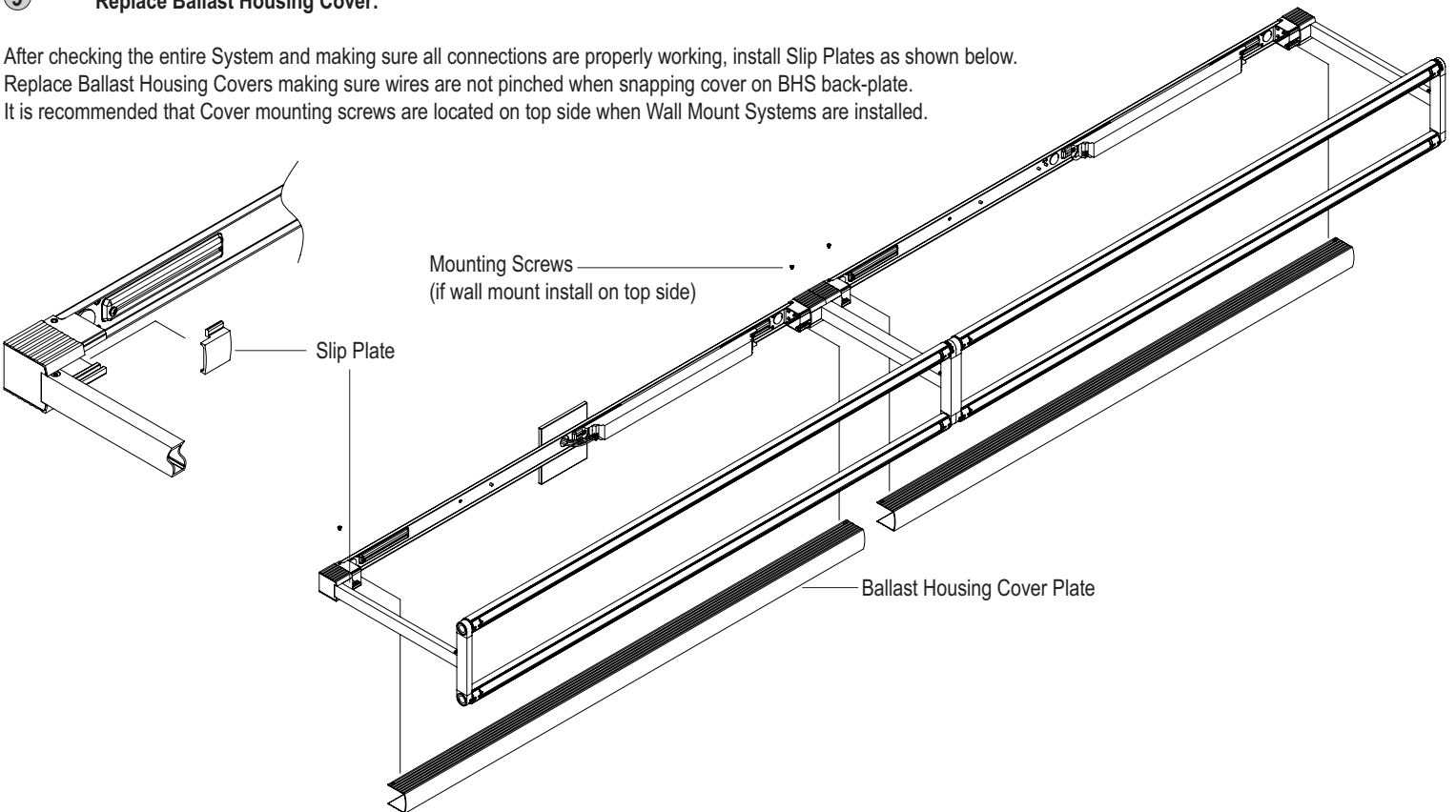

### Integral Ballast and Rail Lengths

Integral Ballast Layout - 2', 3', 4' and 5' Rails

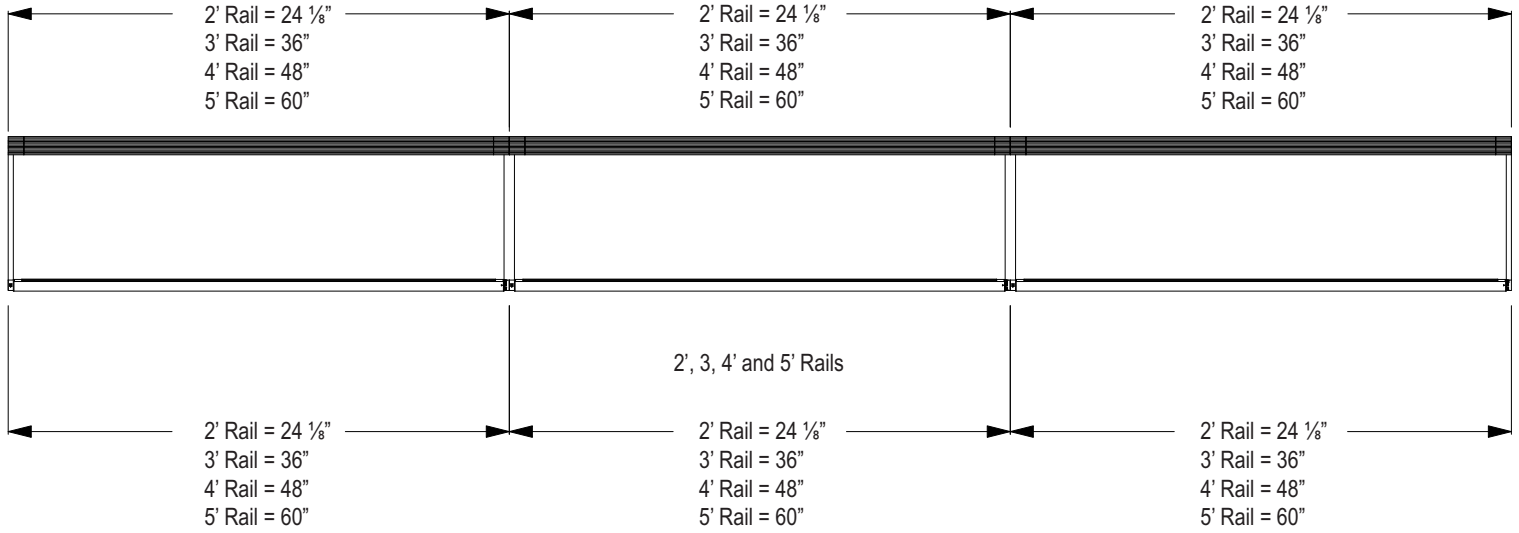

### Back-Plate Knock-out Hole Locations

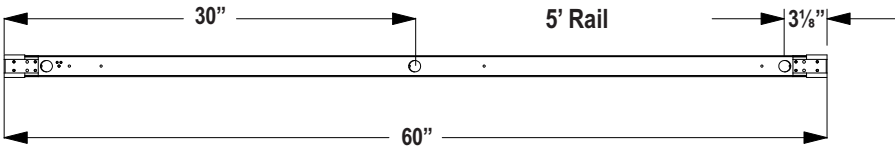
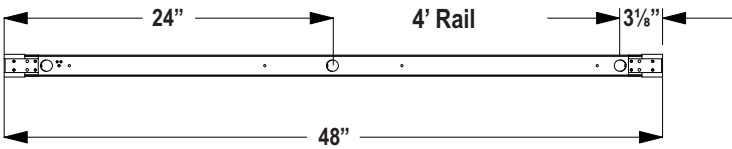
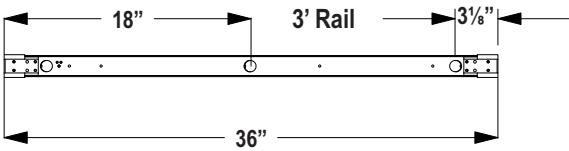
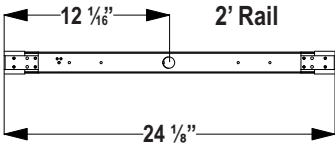

### Wiring Diagram for MLR System

#### 2 - lamp wiring for standard non-dimming programmed-start-ballast

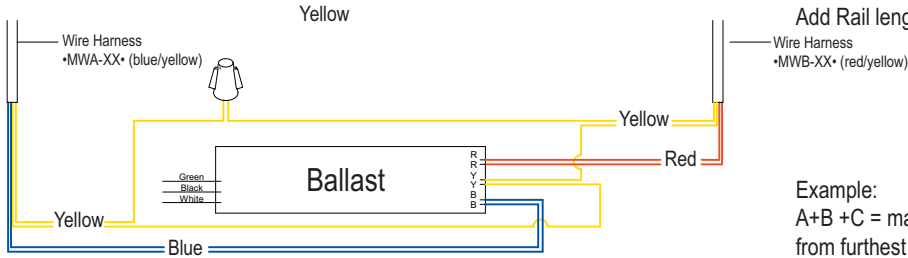

#### IMPORTANT:

Do not exceed maximum allowable distance between ballast and furthest socket. Add Rail length, Half Tee length and Arm-to-Ballast distance in calculation.

Example:  
 $A+B+C =$  maximum distance allowed from furthest socket.

#### 1 - lamp wiring for standard non-dimming programmed-start-ballast

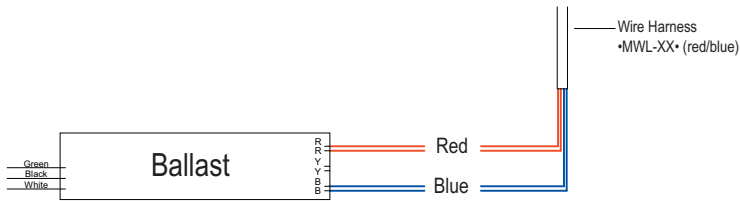

Maximum distance from ballast to **furthest** socket:

Non-dimming programmed-start-ballast	14'
Emergency ballast with Non-dimming ballast	10'
Lutron 10% dimming	7'
Lutron 1% dimming	7'
Lutron Eco-System ballast	7'
Emergency ballast with dimming ballast	7'

NOTE:  
 For dimming and emergency ballast wiring, please contact ballast manufacturer.

