

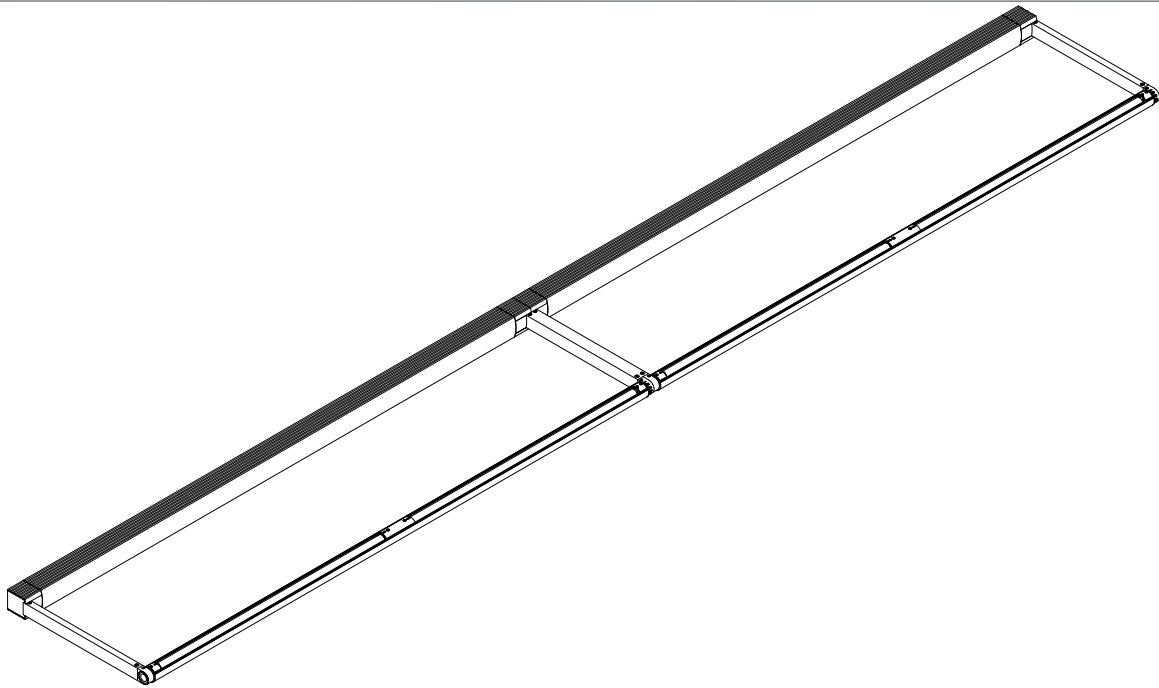

Please read instructions in their entirety before proceeding with any part of the installation. This luminaire must be installed in accordance with the National Electric Code and local regulations. Use of ballasts or other components not supplied by Vode Lighting voids warranty. To prevent electric shock, turn off electricity at the fuse box before proceeding. Do not install this product in wet locations. UL listed for dry and damp locations only. Retain instructions for future reference. Technical Support: 707-996-9898

MLR System - Integral Ballast Housing - 2 lamp - Multi Rail System with 6' or 8' Rails



Components for MLR System • Integral Ballast Housing • 2 lamp • Multi Rail System • Exploded View

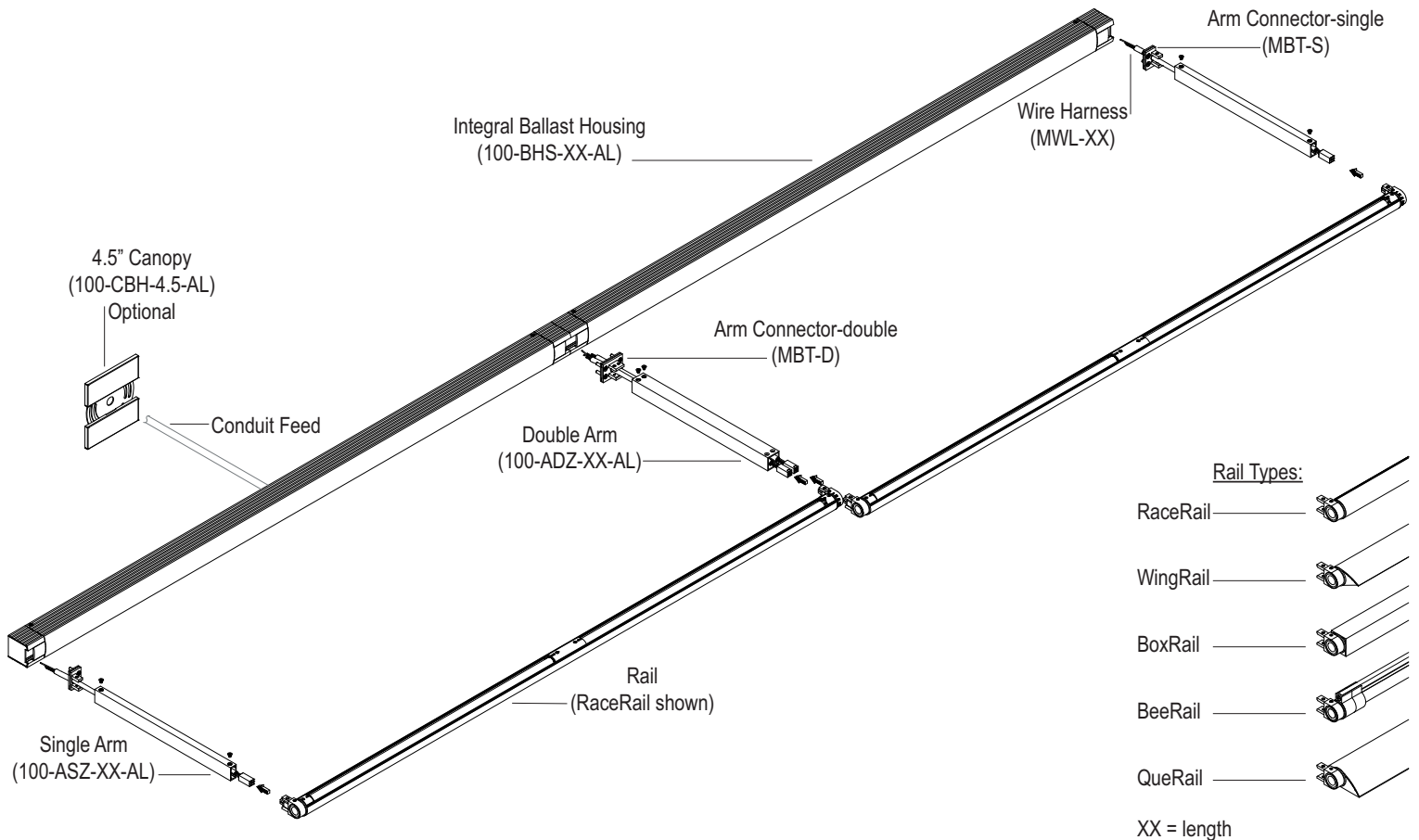

1 Preparing Integral Ballast Housing for Installation:

Remove Ballast Housing Cover, be careful not to damage the finish.
 Remove End Covers on Ends that will be connected.

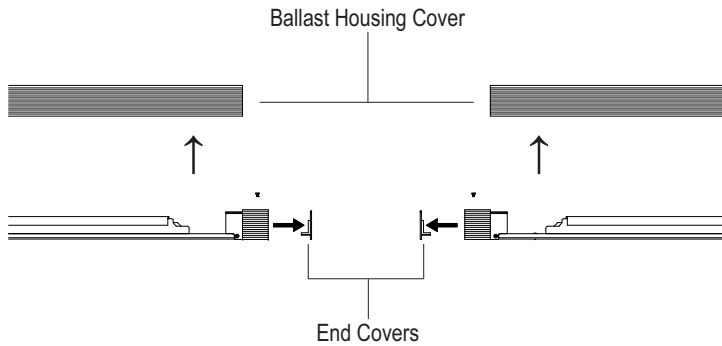

2 Preparing Arms for Installation:

Each Single Arms takes one Wire Harness, Double Arms take two Wire harness.
 Slip Wire Harness through Arm and Arm Connector as shown. (double arm shown)
 Secure Arm to Arm Connector using screws provided as shown.
 Make sure to leave 1" of Wire Harness hanging out of the Arm.

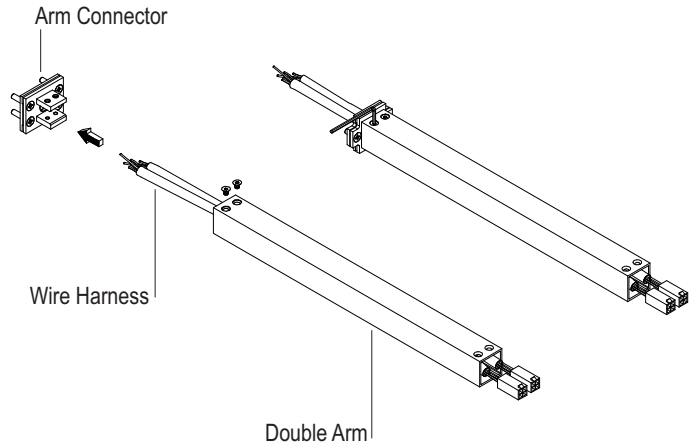

3 Installing Back Plates to Surface using Cover Plates:

Direct conduit feed is recommended but Integral Ballast Housing will mount to any standard j-box. For direct conduit feed see step 4.

Feed Wires through Mounting Plate, secure using provided screws.
 Mounting Plate slots should align with desired mount positions, (vertical or horizontal).
 Insert wires through knock-out holes, most back-plates are provided with 3 knock-out holes, see page 4 for knock-out locations.
 Mounting BHS back-plate to blocking is strongly recommended.
 Install back-plate to surface making sure its leveled and installed exactly between both cover plates. Alignment of first Ballast Housing is critical as it will determine the line of entire System. Secure back-plate to surface using screws provided.
 DO NOT power on System at this time.

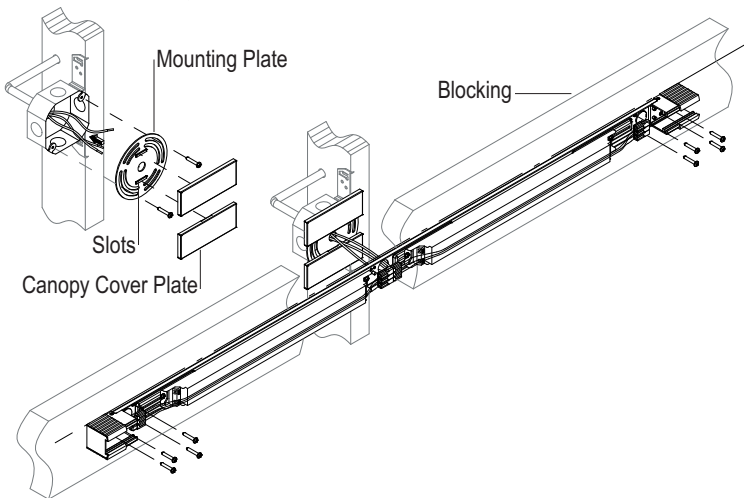

4 Direct Conduit Feed:

Attach conduit to BHS back-plate using conduit adaptor (provided by others).
 Most BHS back-plates are provided with 3 knock-out holes, see page 4 for knock-out locations.
 Mounting BHS back-plate to blocking is strongly recommended.
 DO NOT power on System at this time.

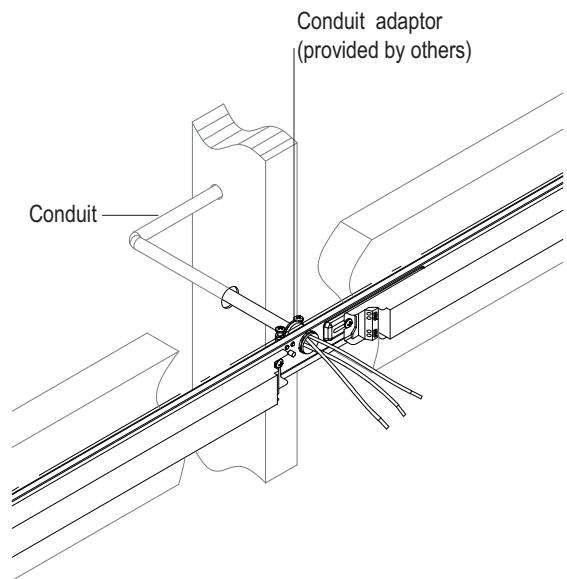

5 Installing Additional BHS Back-Plates:

Install Double Arm on ALL mid-sections, run one Wire Harness to each BHS back-plate. Arms must be centered between BHS End-Block as shown. Align additional sections using Double Arms as guide. Make sure to leave 1" of Wire Harness hanging out of Arm. Make Power Harness (provided by Vode) connections on all mid-sections. Make sure mating connectors are completely secured. Level BHS back-plate and make sure End-Blocks are tight before tightening screws and securing back-plate to surface.

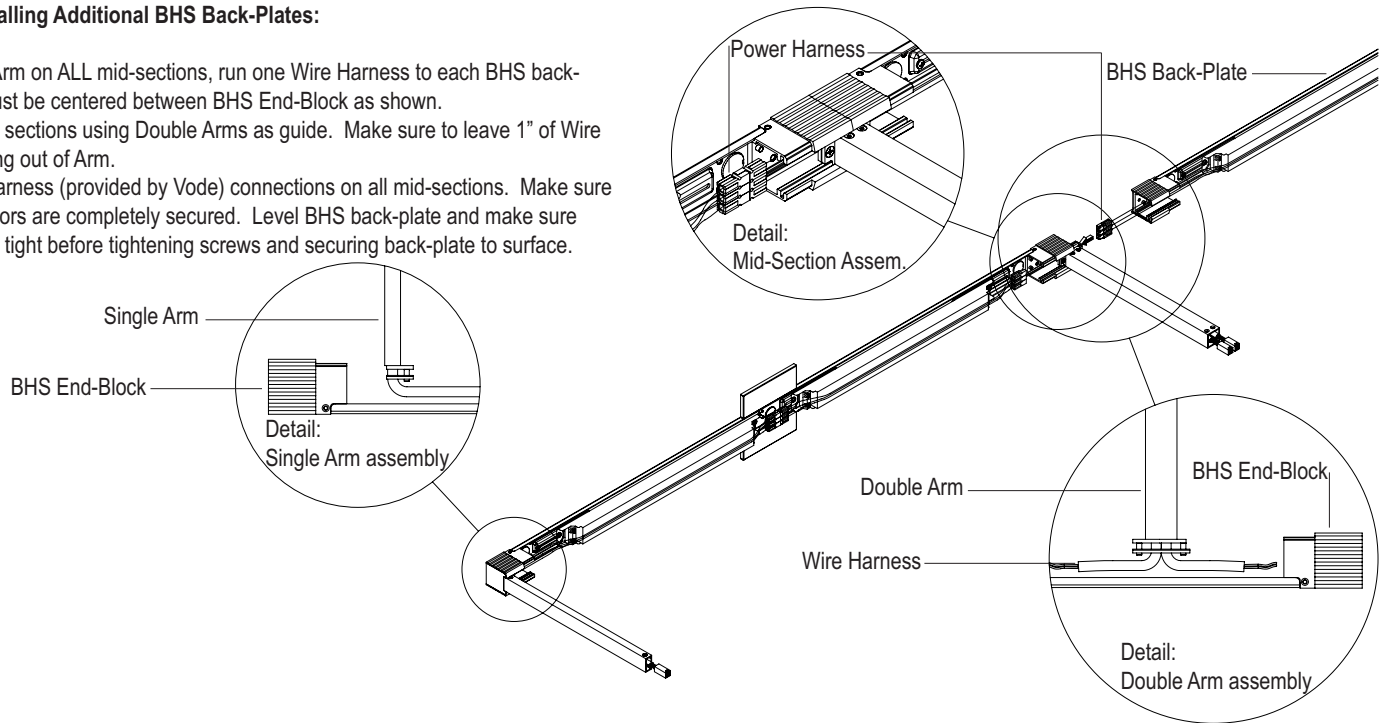

6 Installing Rails:

Snap connector on Wire Harness to mating connector on Rail. Make sure mating connector parts are completely secured. Secure Rail to Arm using screws provided as shown.

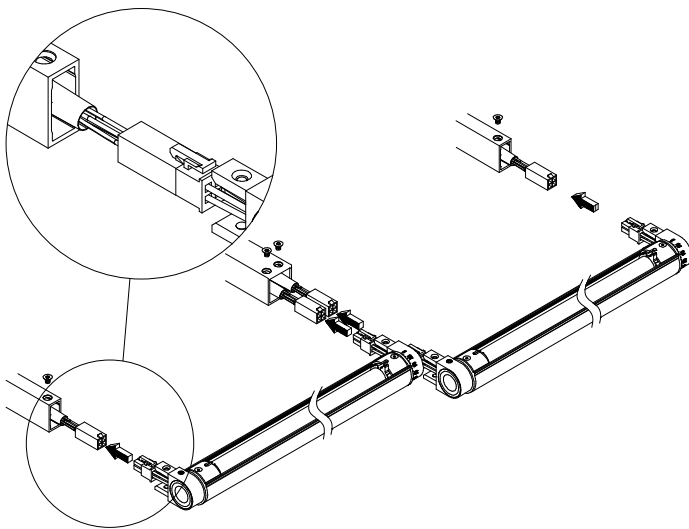

7 Installing Lamps & Adjusting Rails:

IMPORTANT: Use only T5 lamps in correct wattage! See label inside Rail.

Install lamps. For WingRail, BoxRail and RaceRail (shown), turn socket rotor tab to properly position and secure lamp. If lens is applied, install lens. Power-on system and let lamps burn in per lamp manufacturers recommendations (usually 50-100 hours).

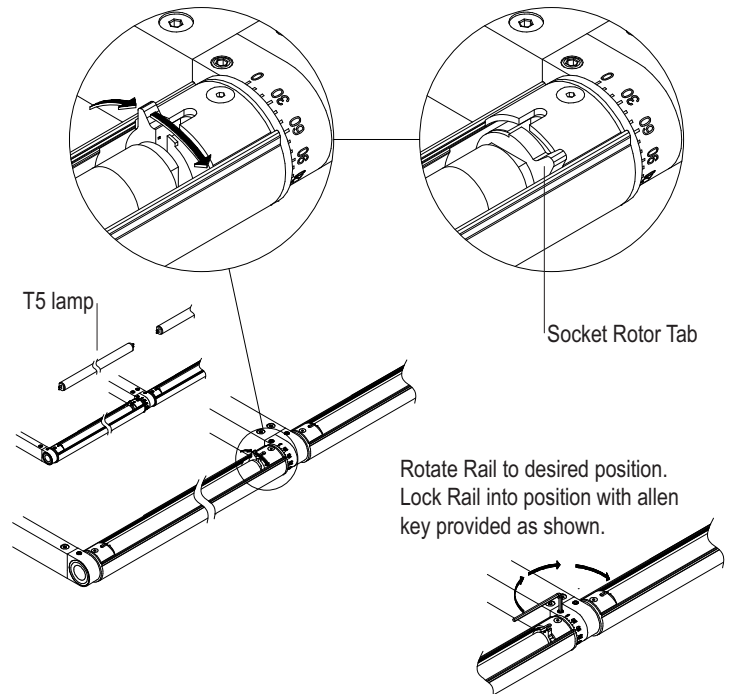

8 Replace Ballast Housing Cover:

After checking the entire System and making sure all connections are properly working, install Slip Plates as shown below. Replace Ballast Housing Covers making sure wires are not pinched when snapping cover on BHS back-plate. It is recommended that Cover mounting screws are located on top side when Wall Mount Systems are installed.

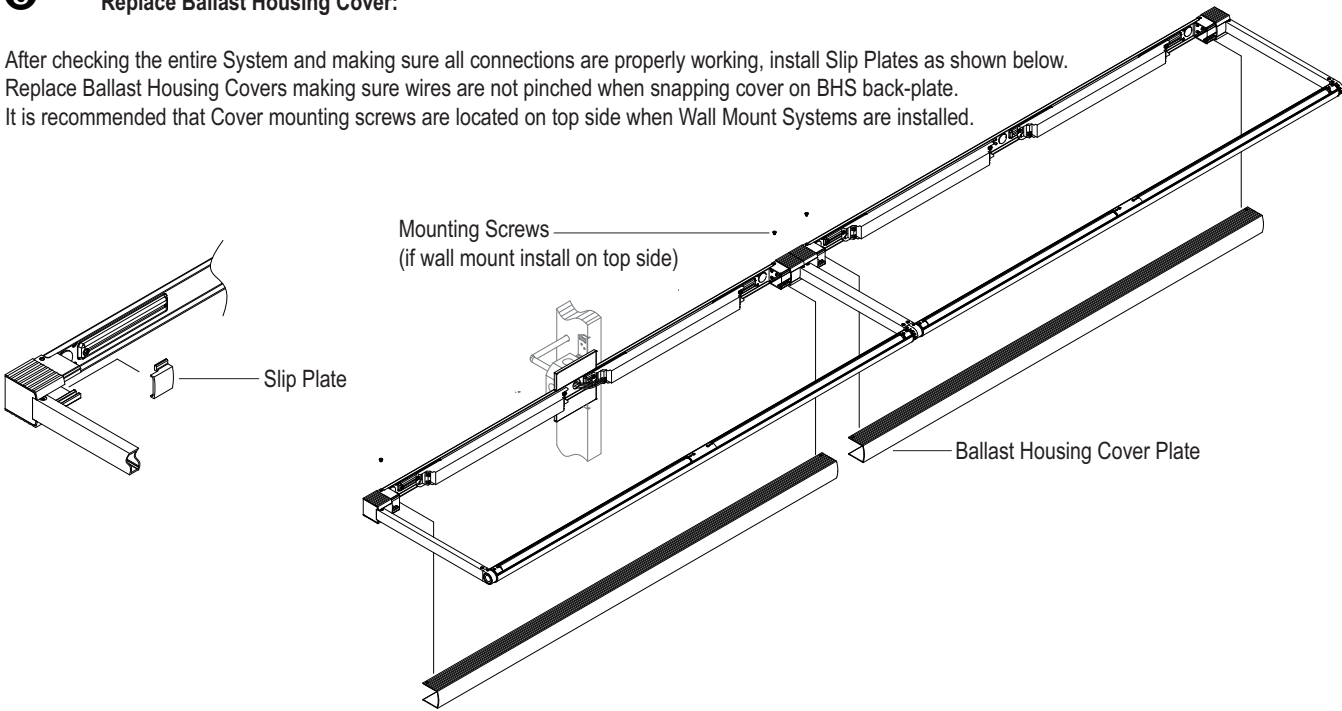

Back-Plate Knock-out Hole Locations

6' Rail

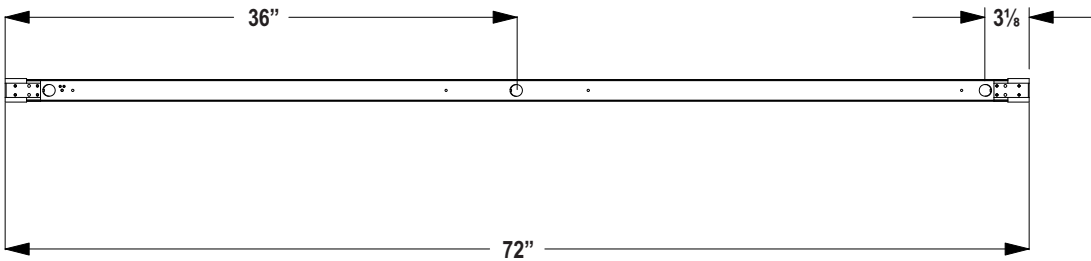

8' Rail

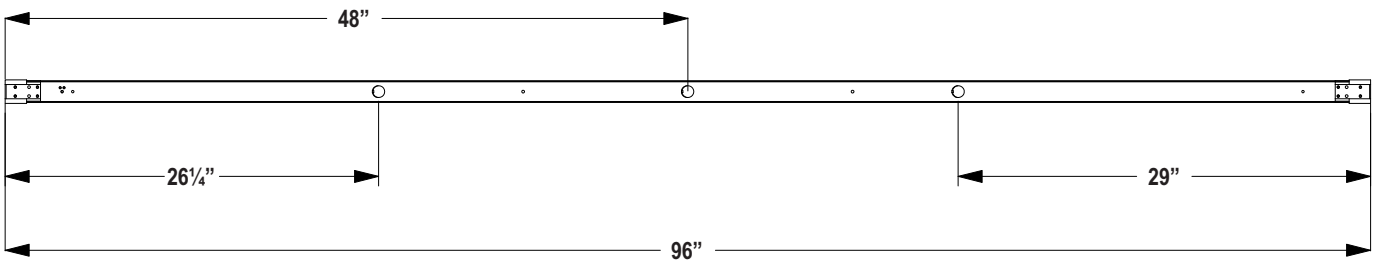

Integral Ballast and Rail Lengths

Integral Ballast Layout - 6' and 8' Rails

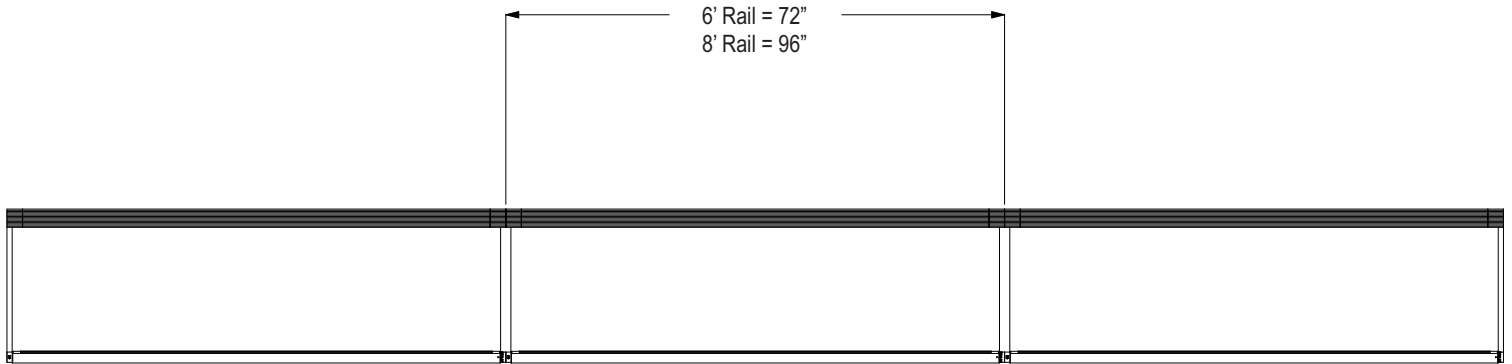

Wiring Diagram for MLR System

1 - lamp wiring for standard non-dimming programmed-start-ballast

Vode wire harness



IMPORTANT:

Do not exceed maximum allowable distance between ballast and furthest socket. Add T5 length, Arm length and Arm-to-Ballast distance in calculation.

Example:
 $A+B+C$ = maximum distance allowed from furthest socket

NOTE:
 For dimming and emergency ballast wiring, please contact ballast manufacturer.

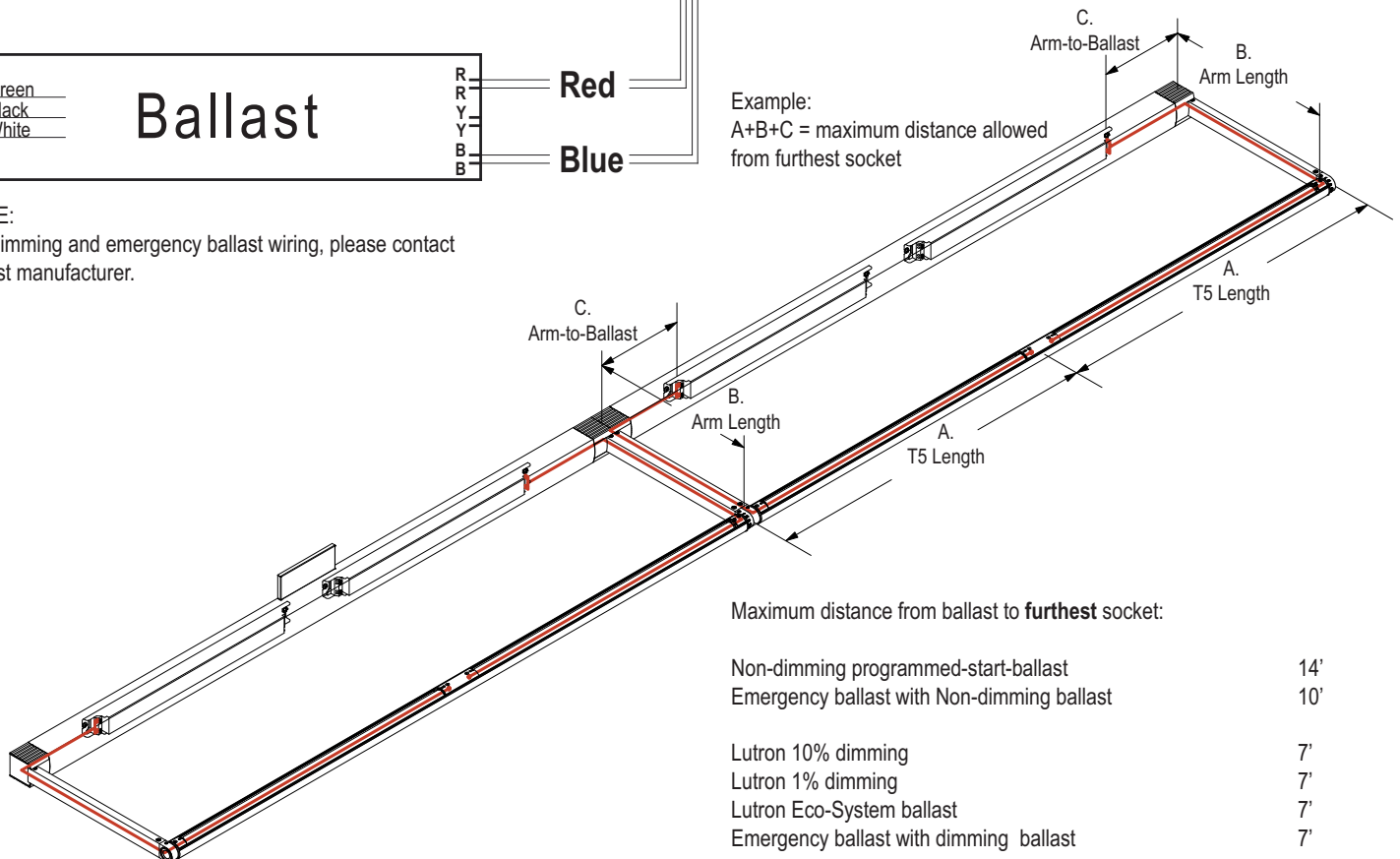

Maximum distance from ballast to **furthest** socket:

Non-dimming programmed-start-ballast	14'
Emergency ballast with Non-dimming ballast	10'
Lutron 10% dimming	7'
Lutron 1% dimming	7'
Lutron Eco-System ballast	7'
Emergency ballast with dimming ballast	7'